

RAVAS-110

A PALLET TRUCK SCALE FROM
THE LEADER IN MOBILE WEIGHING



RAISES EFFICIENCY AND SIMPLIFIES LOGISTIC
PROCESSES, SAVES TIME AND SPACE

FOR CHECKING INCOMING GOODS,
DETERMINING SHIPPING WEIGHTS, AVOIDING
OVERLOADS

5000 LBS CAPACITY AT 2 LBS GRADUATION
STEPS

FOUR AA-BATTERIES ALLOW AN OPERATION
TIME OF 1 YEAR AT 5 WEIGHINGS PER DAY.

LOW POWER CONSUMPTION; AUTOMATIC
SWITCH-OFF

FUNCTIONS

- ◆ Automatic and manual zero correction
- ◆ Gross/net weighing
- ◆ Totalling
- ◆ Error messages in display
- ◆ Automatic switch-off after 3 minutes of non-use
- ◆ Low-bat warning



Indicator functions: zero correction, gross/net weighing, totalling.

DIMENSIONS

A Fork length	:	47.5 inch / 126.65 CM
B Fork width	:	6.7 inch / 170.18 mm
C Minimum fork height	:	3.25 inch / 82.55 mm
D Lifting height	:	8 inch / 203.2 mm
E Width over forks	:	27 inch / 68.58 CM
F Height to top indicator	:	20 inch / 50.8 CM
G Indicator clearance	:	3 inch / 76.2 mm

PRECISION STANDARD VERSION

Graduation : 5000 lbs: graduation 2.0 lbs

STANDARD SPECIFICATIONS

Weighing capacity	:	5000 lbs
Display	:	LCD, height 0.7 inch
Keypad	:	3 function keys, on / off key
Protection class	:	load cells and cabling NEMA 5, indicator NEMA 4
Steering wheels	:	polyurethane
Loading wheels	:	polyurethane, single
Colour	:	red (RAL 3000), epoxy painted
Own weight	:	270 lbs
Batteries	:	6 Vdc by 4 AA batteries
Pump	:	quick lift

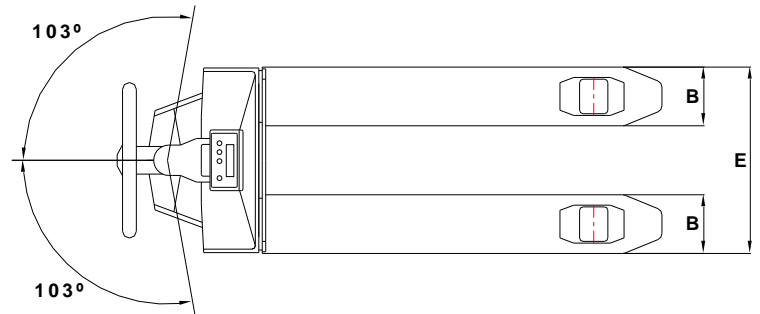
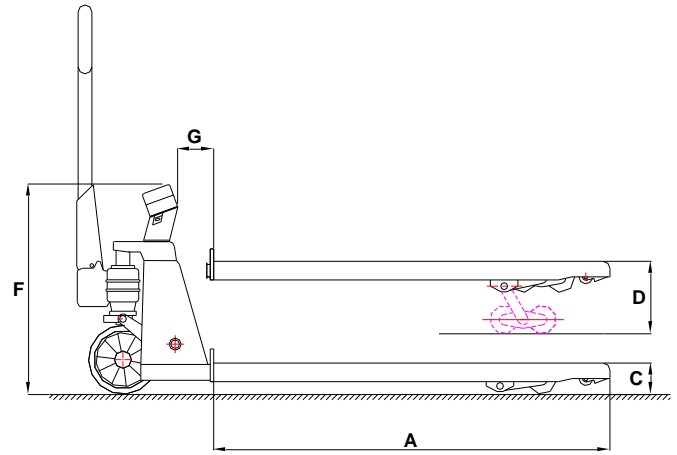

FLOORSCALESDIRECT.COM
A division of Triner Scale & Mfg. Co., Inc

(800) 238-0152