

RAVAS-310

A PALLET TRUCK SCALE FROM THE LEADER IN MOBILE WEIGHING



INCREASES EFFICIENCY AND SIMPLIFIES LOGISTIC PROCESSES, SAVES TIME AND SPACE

NTEP-APPROVED INTEGRATED PRINTER STANDARD

BACKLIGHT INDICATOR FOR EASIER READ OUT

FOR CHECKING INCOMING GOODS, DOSING AND MIXING, DETERMINING SHIPPING WEIGHTS, COUNTING PARTS AND DATA COMMUNICATION

PIECE COUNTING PROGRAM WITH PIECE WEIGHT SAMPLING

THREE DIFFERENT COMMUNICATION PROTOCOLS FOR DATA TRANSFER TO HANDHELD TERMINAL, PC OR WMS

HIGH ACCURACY: MAXIMUM ERROR 0.1% OF THE APPLIED WEIGHT

EASILY EXCHANGEABLE BATTERY PACK FOR CONTINUOUS USE; CHARGER INCLUDED

FUNCTIONS

- ◆ Automatic and manual zero correction
- ◆ Gross/net weighing
- ◆ Automatic and manual tare
- ◆ Totalling with sequence number
- ◆ ID-code entry (5-digit)
- ◆ Piece counting by sampling
- ◆ Piece counting by entry of piece weight
- ◆ Printing of date, time, counted pieces, gross/net weight, total weight
- ◆ Internal clock
- ◆ Error messages in display
- ◆ Automatic shut off after 30 minutes of non-use
- ◆ Lbs/kg toggle function



RAVAS

Standard NTEP approved (Legal for Trade), industrial exchangeable battery pack and integrated thermal printer.

DIMENSIONS

A	Fork length	:	47.5 inch/120.65 CM
B	Fork width	:	6.7 inch/170.18 mm
C	Minimum fork height	:	3.25 inch/82.55 mm
	Minimum space between floor and forks	:	0.87 inch/22 mm
D	Maximum fork height	:	8 inch/203 mm
	Lifting height	:	4.75 inch/120.65 mm
E	Width over forks	:	27 inch/68.58 CM
F	Height to top indicator	:	30 inch/76 mm

PRECISION STANDARD VERSION

Max. inaccuracy : 0.1% of the applied weight

Graduation : 5000 lbs: graduation 2.0 lbs

STANDARD SPECIFICATIONS

Weighing capacity	:	NTEP approved 5000 lbs x 2 lb graduation steps
Display	:	LCD, height 0.7 inch, with backlight and date and time memory
Keypad	:	5 function keys; on / off key, piece counting, print, tare, zero
Printer	:	Thermal printer
Protection class	:	load cells and cabling NEMA 5, indicator NEMA 4
Steering wheels	:	polyurethane
Loading wheels	:	polyurethane, single
Color	:	red (RAL 3000), epoxy painted
Own weight	:	285 lbs
Battery	:	12 Vdc / 1.2 Ah industrial battery pack, exchangeable and rechargeable; charger included
Battery life	:	35 hours, low voltage indication
Charger	:	230 Volt / 12 Vdc - 300 mA
Charging time	:	approximately 6 hours
Pump	:	quick lift

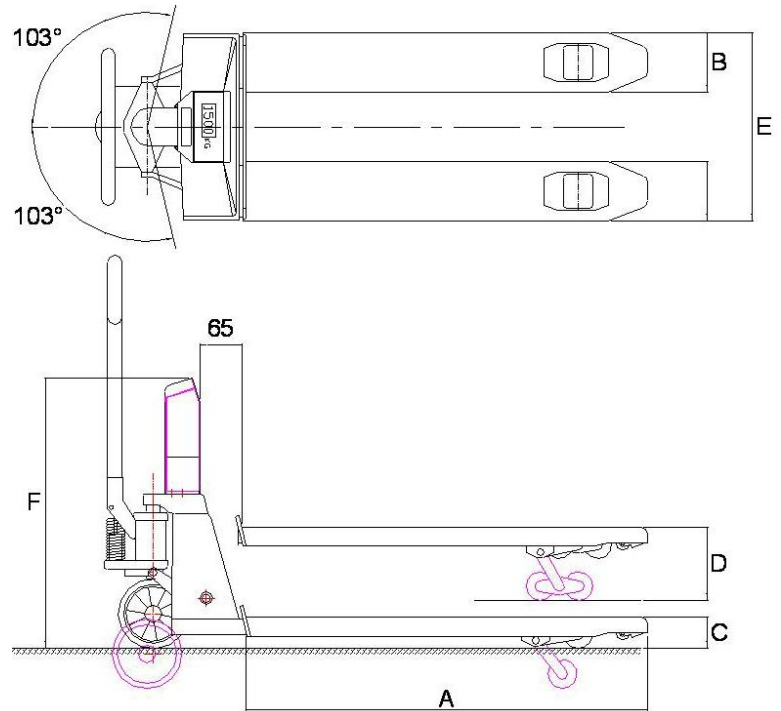

Indicator 310	
<i>Print example</i>	
CODE	12345
B/G	1234 lb
T	34 lb
N	1200 lb
<i>Piece counting example</i>	
PcWt	1200 lb
Qty	1200 Pcs
<i>Total print example</i>	
Tot. B/G	1234 lb
Tot. T	34 lb
Tot. N	1200 lb
Nr.	1
10/07/06	17:45

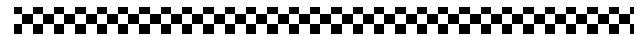

OPTIONS WEIGHING SYSTEM

- Bluetooth® signal output
- RAVAS SIR Mobile software for integration with Microsoft Windows® CE 5.0 / Mobile 5.0 platforms
- NTEP approval 3000 lbs x 1 lb
- Multi-range graduation:
 - 0-500 lbs x 0.5 lb
 - 500-1000 lbs x 1 lb
 - 1000-5000 lbs x 2 lbs
- Extra exchangeable battery

OPTIONS HAND PALLET TRUCK

- Width over forks 21 inch

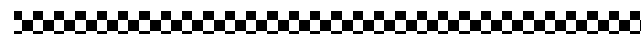

FLOORSCALESDIRECT.COM
A division of Triner Scale & Mfg. Co., Inc
(800) 238-0152